

REVISED AGENDA
COOS COUNTY BOARD OF COMMISSIONERS
Owen Building Large Conference Room
May 20, 2019
8:30 A.M.

1. **EXECUTIVE SESSION under the authority of ORS 192.660**

- A. (2)(e) Real Property Transactions
- B. (2)(h) Consultation with Counsel

PLEDGE OF ALLEGIANCE

2. **CITIZEN COMMENTS (agenda items or general comments) – limited to 3 minutes per person- scheduled to begin at 9:30 AM**

3. **DEPARTMENT HEADS**

- A. Request Approval of MOU with SWOIPA & Authorize Director to Sign- Coos Health & Wellness (CHW)
- B. Request Approval of Contract for Video Production Services- CHW
- C. Request Approval to Transfer Funds from Parks Contingency Fund- Parks
- D. Request Approval to Transfer Funds from General Fund Contingency Fund- Jail

4. **CONSENT CALENDAR- administrative matters not up for discussion**

- A. **Approval of Minutes**
Regular Meeting Minutes- May 7, 2019
- B. **Ratification of All Routine Expenditures, Tax Overpayments and Adjustments and Transfer of Funds Within the Budget**
Transfer of Appropriation Within Department- DA Support Enforcement- extra help
Transfer of Appropriation Within Department- Road Maintenance- storm & culvert project supplies
Transfer of Appropriation Within Department- SW Closure/Post Closure- shortage in payroll
Transfer of Appropriation Within Department- Finance/Tax- shortage in payroll
- C. **Orders & Resolutions**
Resolution 19-05-072P, In the Matter of Granting a Merit Step Salary Increase for Shelly Dubisar Retroactive to April 1, 2019
Resolution 19-05-073P, In the Matter of Granting Salary Merit Step Increases for Various Employees Effective May 1, 2019
Resolution 19-05-074P, In the Matter of a Pay Grade Adjustment for Kelsey Orr Pursuant to the Side Agreement Between Coos County and ONA Effective May 1, 2019
Resolution 19-05-075P, In the Matter of Classifying and Placement of Various Employees on the Regular Coos County Payroll Effective Their Various Hire Dates
Resolution 19-05-077B, In the Matter of a Transfer of Expenditure Appropriations in the Amount of \$8,095 Within the General Fund
Resolution 19-05-078B, In the Matter of a Transfer of Expenditure Appropriations in the Amount of \$1,670 Within the Crime Victims Assistance Fund
- D. **Items Previously Approved (authorize Chair to sign where necessary)**
Contract with South Coast Head Start- CHW- WIC coordination/services
Contract Amendment with Western Mercantile- CHW- collection services
Contract Amendment with Creative Creations Landscaping- CHW- 305 LaClair property
Contract Amendment with North Pacific Security- CHW- security at CHW buildings
Agreement with Ronald Broadley- CHW- relocation expenses
Agreement with Group Connections Project- CHW- child/family development assistance

This agenda does not limit the ability of the Commissioners to consider additional subjects. The Board reserves the right to place a time limit on public testimony on any matter. The meeting place is handicapped accessible; if special accommodation is needed, please contact the office at least 24 prior to the meeting.

Liquor License Renewals for the Following; 4 Corners 4, Bandon Crossings (2), Bandon Dunes (2), Coos Bay Speedway, Coquille Tackle and Smokes, Coquille Valley Elks #1935, Davey Jones Locker, Old General Store, Sunset Market, Portside, Miller's at the Cove

5. LATE AGENDA ITEMS

- A. Request Approval to Purchase & Install Signage- CHW
- B. Request Approval of Resolution to Initiate Vacation Proceedings- County Counsel
- C. Request Approval of Agreement with Coquille Indian Tribe for COPS Grant Funding- County Counsel

6. COMMISSIONERS REPORTS

BOC only:
Consent Agenda _____
Regular Agenda _____

LATE AGENDA ITEM COVERSHEET

Agenda Item Title: Advanced Health – CHW Building Signs

Department: Coos Health & Wellness

Requested Agenda Date: 05/07/2019²⁰

Contact Person: Mike Rowley

Phone/Ext.: 541-266-6778

Background and description of need or problem: Advanced Health and Coos Health & Wellness will add a combined monument sign at the street to let the public know where the entrance to our buildings are. Currently neither of us have any signs for our new facilities.

No County General Funds will be used for this contract.

Funding Source: 021-1300-441.60-01

Requested Action: Approve to purchase through Advanced Health. Advanced Health will pay for the entire sign and CHW will pay them our portion of \$12,350.00

Date: 04/10/2019

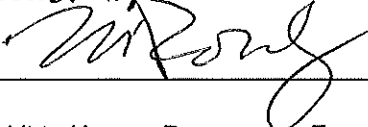
Signature of Dept. Head: 

If this is a Human Resources issue, forward to the Treasurer who will forward it to Human Resources. For all other matters, forward the document to Counsel no later than the Monday prior to the Agenda deadline. Counsel will forward to Treasurer.

If this is a contract or grant:

- Is the contract or grant an original?
- Is the Contract/Grant Summary Form attached?
- Is the contract signed first by the vendor (except state/federal grants or contracts)?
- If insurance is required, is the insurance certificate attached?
- Is the Clerk's Coversheet attached or do you want it returned to you for filing?

Departments Affected:

Counsel: NJ - under Common Area Maintenance Agreement.

Treasurer: 

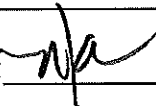
Human Resources: 

BOC forwards signed Contract/Grant to:

5A

COLT SIGNS INCORPORATED

310 S ADAMS STREET - COQUILLE - OREGON - 97423 - KYLE@COLTSIGNS.COM - (541)396-2057

Coos Health & Wellness Old Growth CVG Redwood Sign Plaque (Estimate)

Staci Leep & Eric Gleason

March 12, 2019

2) 3' - 0" x 6' - 0" x 1 1/2" Salvaged (Recycled Redwood) Kiln dry CVG Old Growth Sandblasted and Engraved Redwood Signs, Hardened Enamel Finished on all Elevated Text, Borders and Logos. Background and Edges are Alykd-Oil Base painted with a stain finish. Recess supports for metal covers on side edges of signs for Coos Health & Wellness, Advanced Health and OCCA Signs.

Total \$4,140.00

2) 3' - 0" x 6' - 0" x 1 3/4" Mint Condition (New Redwood) Kiln dry CVG Old Growth Sandblasted and Engraved Redwood Signs, Hardened Enamel Finished on all Elevated Text, Borders and Logos. Background and Edges are Alykd-Oil Base painted with a stain finish. Recess supports for metal covers on side edges of signs for Coos Health & Wellness, Advanced Health and OCCA Signs.

Total \$5,760.00

**No Installation Included, No Permits Included, or Metal Covers Included

** Price may change after 60 days

Ken Wirebaugh

Colt Signs, Inc.

CCB 111682

signs only

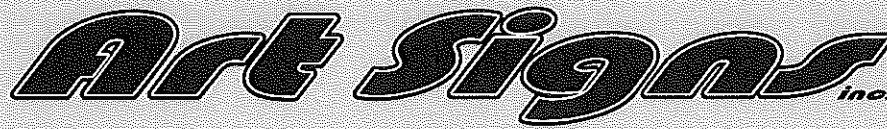

63006 Hwy 101 S. Coos Bay, Oregon
Ph. 541 267-7894 Fx 267-3514

Estimate for: Coos Health & Wellness 4-8-19

Cost estimate to manufacture steel structure, set in concrete footing, and install redwood signs made by others. two 6" square tube poles 17' long set 5' deep in concrete footing, weld on mounts for redwood signs, all steel to be painted with primer and two finish coats of paint, manufacture and install edge fillers between the backs of signs, made from .063 aluminum, painted to match. \$11,235.

add decorative masonry work at base of poles, estimated ballpark cost of \$5,000.

permit procurement \$185.

Thank You,

Tracy Mueller

*Note: Permits not included in price.

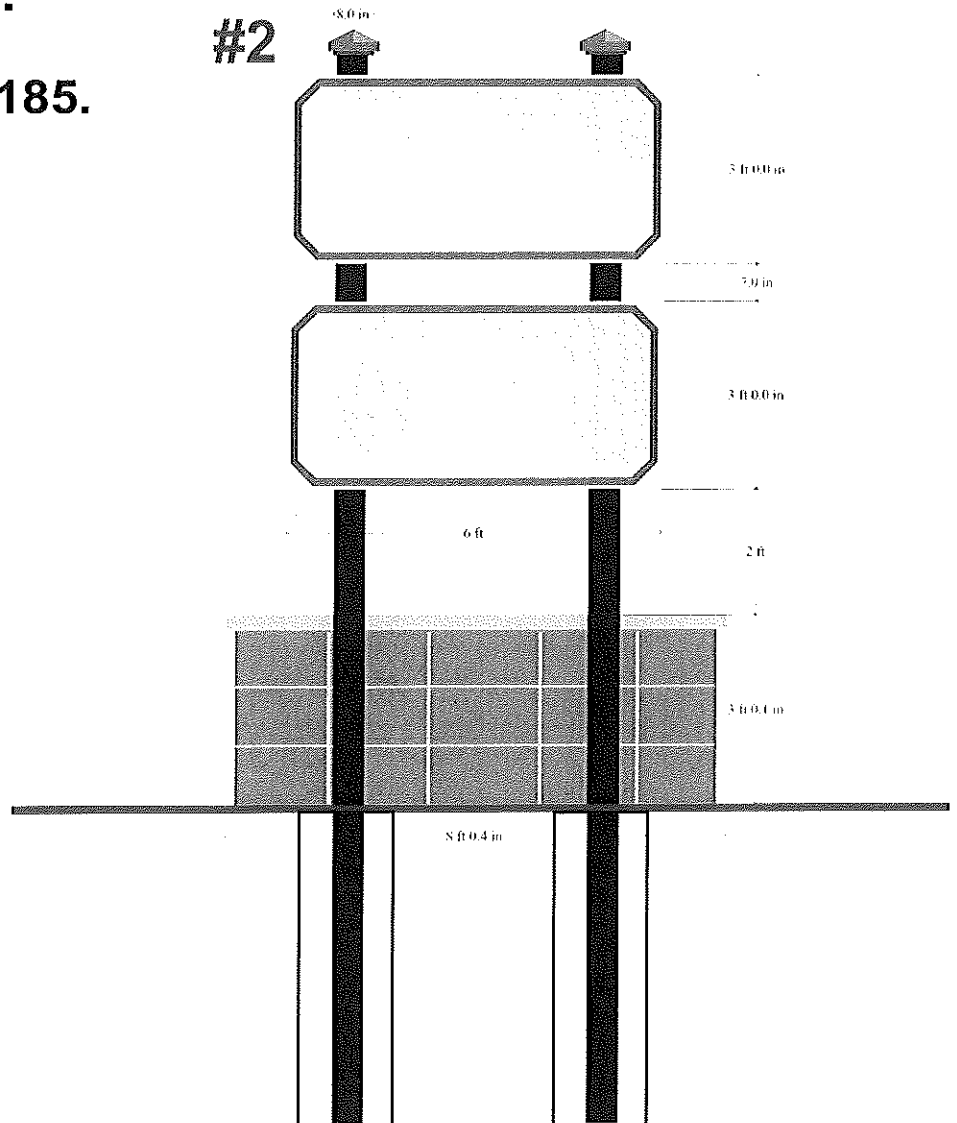

Installation only

BOC only:
Consent Agenda _____
Regular Agenda _____

LATE **AGENDA ITEM COVERSHEET**

Agenda Item Title: Initiate Vacation Proceedings for Public Property

Department: Counsel

Requested Agenda Date: 5/20/19

Contact Person: Colton Totland

Phone/Ext.: 7690

Background and description of need or problem: The County may vacate a part of a subdivision or any other public property under ORS 368.341(2). The County intends to vacate property that was dedicated to the County as a public park in 1972 described as Lot 32, Block 1, Majestic Shores, Division 1. The sale of the property would support County services. The first step in this process is for the Roadmaster to prepare and file a written report determining if this is in the public interest. This process is set out in Resolution 19-05-079L.

Funding Source: n/a

Requested Action: Approve Resolution 19-05-079L initiating the vacation proceedings.

Date: 5/16/19

Signature of Dept. Head: Colton Totland

If this is a Human Resources issue, forward to the Treasurer who will forward it to Human Resources. For all other matters, forward the document to Counsel **no later than the Monday prior to the Agenda deadline.** Counsel will forward to Treasurer.

If this is a contract or grant:

- Is the contract or grant an original?
- Is the Contract/Grant Summary Form attached?
- Is the contract signed first by the vendor (except state/federal grants or contracts)?
- If insurance is required, is the insurance certificate attached?
- Is the Clerk's Coversheet attached or do you want it returned to you for filing?

Departments Affected:

COUNSEL: CT

TREASURER: _____

BOC forwards signed document to Counsel's office.

5B

Approved as to form:

BOARD OF COMMISSIONERS

Cotton Tottland

Office of Legal Counsel

Chair

Commissioner

Commissioner

BOC only:
Consent Agenda _____
Regular Agenda _____

LATE AGENDA ITEM COVERSHEET

Agenda Item Title: Agreement with Coquille Indian Tribe for COPS Grant funding

Department: Counsel/Sheriff's Office **Requested Agenda Date:** 5/20/2019

Contact Person: Nathaniel Johnson **Phone/Ext.:** 7690

Background and description of need or problem: The Coquille Tribe has agreed to allocate \$46,618.00 funds from a US DOJ COPS Grant to fund a Patrol Vehicle purchase by the Sheriff's Office. Tribal Council approved the Memorandum of Agreement allocating this grant funding on May 9, 2019.

Funding Source: Coquille Indian Tribe grant funding

Requested Action: Approve the Memorandum of Agreement with the Coquille Tribe for the allocation of \$46,818.00 to the County for the purchase of a Patrol Vehicle.

Date: 5/16/19 Signature of Dept. Head: Nathaniel Johnson

If this is a Human Resources issue, forward to the Treasurer who will forward it to Human Resources. For all other matters, forward the document to Counsel **no later than the Monday prior to the Agenda deadline.** Counsel will forward to Treasurer.

- If this is a contract or grant:
- Is the contract or grant an original?
 - Is the Contract/Grant Summary Form attached?
 - Is the contract signed first by the vendor (except state/federal grants or contracts)?
 - If insurance is required, is the insurance certificate attached?
 - Is the Clerk's Coversheet attached or do you want it returned to you for filing?

Departments Affected:

COUNSEL: NT

TREASURER: NS

BOC forwards signed document to Counsel's office.

50

CONTRACT / GRANT SUMMARY FORM

Clerk's CJ No.: _____ (complete after filed with Clerk)

Contract/Agreement/Grant No.:

Name/Agency Name and Address: Coquille Indian Tribe, 3050 Tremont Street, North Bend, OR 97459

Contact Person: Scott LeFevre Phone No. 541.888.0189

Amount of Contract/Grant Award: \$ \$46,618.00

Payment Terms: invoice from Tribe (state lump sum or amount and time of payments)

Start Date: upon execution of MOU End Date: when any party terminates with 30 days' notice to other party

County Department and Employee Responsible for Performance: Sheriff's Office / Craig Zanni

Description: MOU between County and Coquille Tribe to allocate funding for purchase of patrol vehicle and accessories.

FINANCIAL INFORMATION

STATE %	OTHER %	FEDERAL % (CFDA # Required)	Catalog of Federal Domestic Asst. *(CFDA) Number
		<u>100%</u>	<u>16.710</u>

*CFDA is a five digit number in the following format: xx.xxx. The first two digits designate the federal agency and the last three the grant description. The following is a partial listing of the two digit agency identifier:

- 10.xxx USDA 14.xxx HUD 20.xxx USDOT 66.xxx EPA 84.xxx Dept. of Education
 11.xxx Dept. of Commerce 16.xxx USDOJ 39.xxx General Svcs. Admin. 83.xxx FEMA 93.xxx USDHHS

NOTE: If the contract/grant is associated with more than one CFDA number, each segment must have it's own summary form.

New

Renewal

Modification

Previous Amount: \$

Original Amount: \$

Previous Date:

Original Date:

Automatic Renewal? Yes No

Staff Requirements: New Existing Subcontract

Will unemployment cost be incurred? Yes No

PUBLIC CONTRACTING INFORMATION

Method of Selection:

- Bid None
 Quote Other MOU
 Proposal

Type of Contract:

- New (complete sections below)
 Renewal (no need to complete sections below)
 Modification (no need to complete sections below)

Type of Contract:

Goods and Services - If Not Using Bid or Proposal, Mark Exemption:

- | | |
|---|--|
| <input type="checkbox"/> Under \$10,000 | <input type="checkbox"/> Equipment Maintenance |
| <input type="checkbox"/> Under \$50,000 for Quotes | <input type="checkbox"/> Office Supplies |
| <input type="checkbox"/> Under \$150,000 & Approval from Board for Quotes | <input type="checkbox"/> Used Vehicles |
| <input type="checkbox"/> Sole Source | <input type="checkbox"/> State Purchasing |
| <input type="checkbox"/> Contract with Public Agency | <input checked="" type="checkbox"/> Other <u>Memorandum of Understanding</u> |

Public Improvement - If Not Using Bid, Mark Exemption:

- | | |
|--|---|
| <input type="checkbox"/> Under \$5,000 | <input type="checkbox"/> Alternative Contracting Method Approved by Board |
| <input type="checkbox"/> Under \$50,000 for Quotes | <input type="checkbox"/> Other _____ |
| <input type="checkbox"/> Under \$100,000 & Not a Transportation Project for Quotes | |

Personal Services Contract - If Not Using Proposal, Mark Exemption:

- Under \$50,000
 Under \$150,000 & Approval from Board

Will project be reported to Bureau of Labor for Prevailing Wages under ORS 279C.800? Yes No

Certificate of insurance required? Yes No

Form of contract: Oral Written (attach the written contract)

Date Approved by BOC: _____ Reviewed by Counsel: MS